

TANKER TRUCKS (AIR GAP & RP)

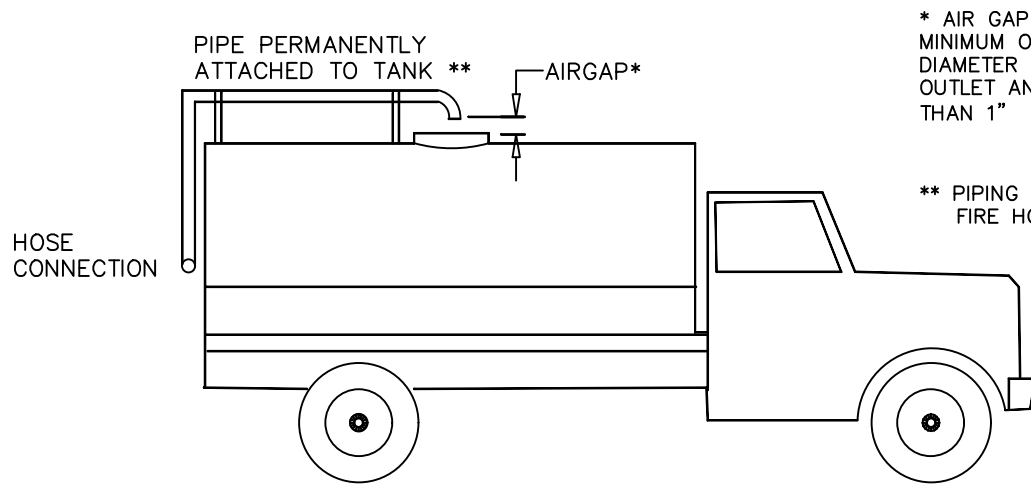

* AIR GAP MUST BE A MINIMUM OF 2X THE DIAMETER OF THE SUPPLY OUTLET AND NEVER LESS THAN 1"

** PIPING MUST BE "HARD-PIPED". FIRE HOSE IS NOT ACCEPTABLE.

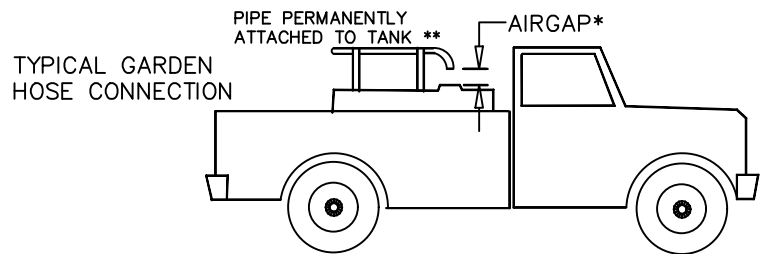

FIGURE A - AIR GAP

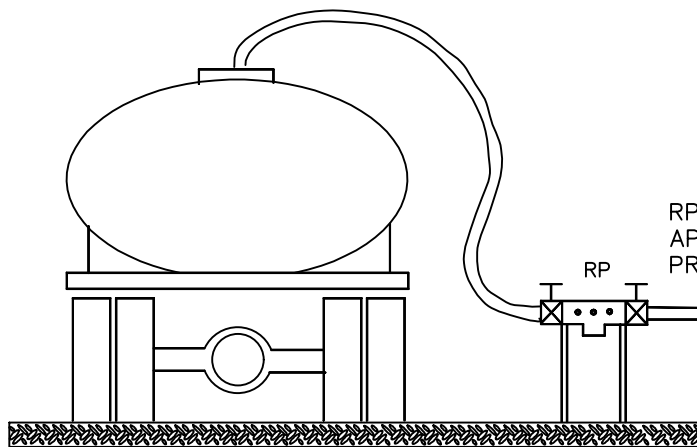
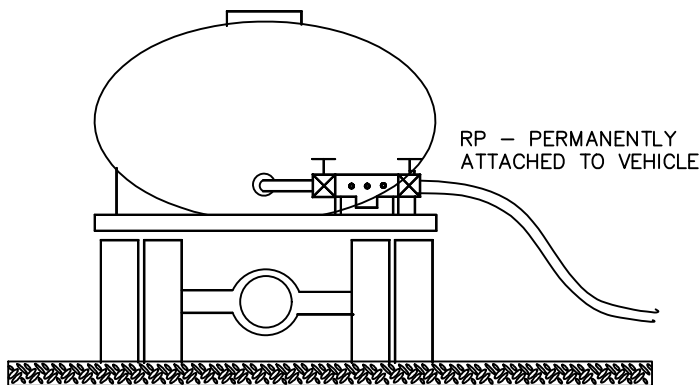

FIGURE B - RP

NOTE:
ALL TANKS SHALL SUPPLY A CUBIC FOOT REGISTER METER.

RP = A SALISBURY-ROWAN UTILITIES APPROVED REDUCE-PRESSURE PRINCIPLE ASSEMBLY.

CITY OF SALISBURY, N.C. STANDARD DETAIL

DATE: OCTOBER 17, 2006

STANDARD DETAIL BACKFLOW PREVENTION
TANKER TRUCKS (AIR GAP & RP)

NOT TO SCALE

STANDARD

BF-12