

FOR ASPHALT PAVEMENT
OVER CONCRETE

FOR ASPHALT PAVEMENT

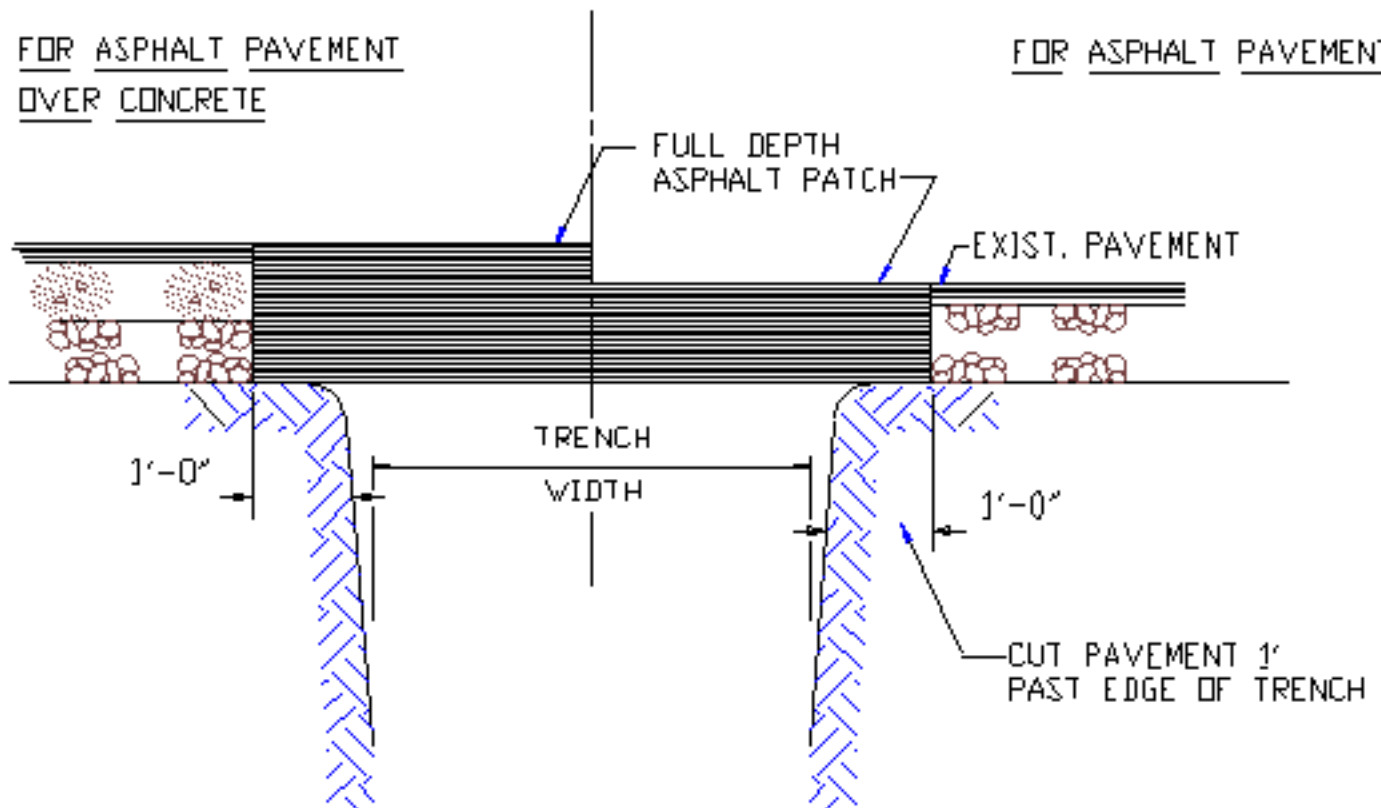

NOTES:

1. IF ARRANGEMENTS HAVE BEEN MADE WITH THE CITY FOR CITY FORCES TO REPLACE ASPHALT, STONE SHALL BE PLACED FLUSH WITH THE EXISTING SURFACE FOR A MINIMUM DEPTH OF 10 INCHES.
2. OPEN CUTTING OF STATE ROADS MUST BE APPROVED BY NCDOT, AND REPAIRS MUST BE MADE IN ACCORDANCE WITH NCDOT REQUIREMENTS.
3. EXISTING ASPHALT SHALL BE REMOVED FOR A DISTANCE OF 1 FOOT TO BOTH SIDES OF THE TRENCH OPENING.
4. ASPHALT PATCH TO BE 1-2 ASPHALT.

CITY OF SALISBURY, N.C. STANDARD DETAIL

DATE: JANUARY 1, 1991

PIPELINE INSTALLATION
PAVEMENT REPAIR

NOT TO SCALE

STANDARD

P-5