

NOTES:

1. MANHOLE BASE SHALL BE 4000 PSI CONCRETE PLACED ON UNDISTURBED EARTH AND MAY BE PLACED AGAINST SHAPED BANKS IN LIEU OF FORMS.
2. CONTRACTOR SHALL NOT CUT THE EXISTING SEWER PIPE UNTIL PERMISSION IS GRANTED BY THE SRU INSPECTOR - AFTER FINAL PROJECT APPROVAL.
3. WRAP OUTSIDE MANHOLE SEAMS (JOINTS) WITH WIDE BUTYL TAPE.
4. MANHOLE TO CONFORM TO CITY STANDARDS AND SPECIFICATIONS FOR PRECAST MANHOLES (SECTION II - PART 3, 3.04).
5. ALL MANHOLES ARE REQUIRED TO BE VACUUM TESTED.

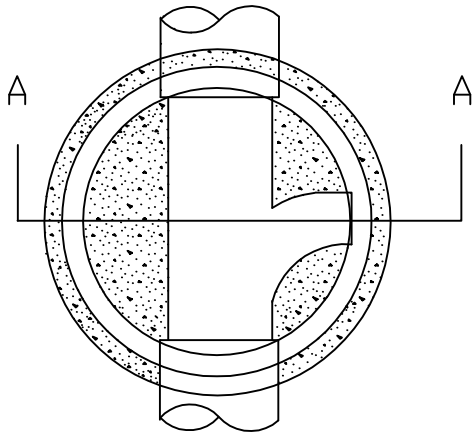

PLAN

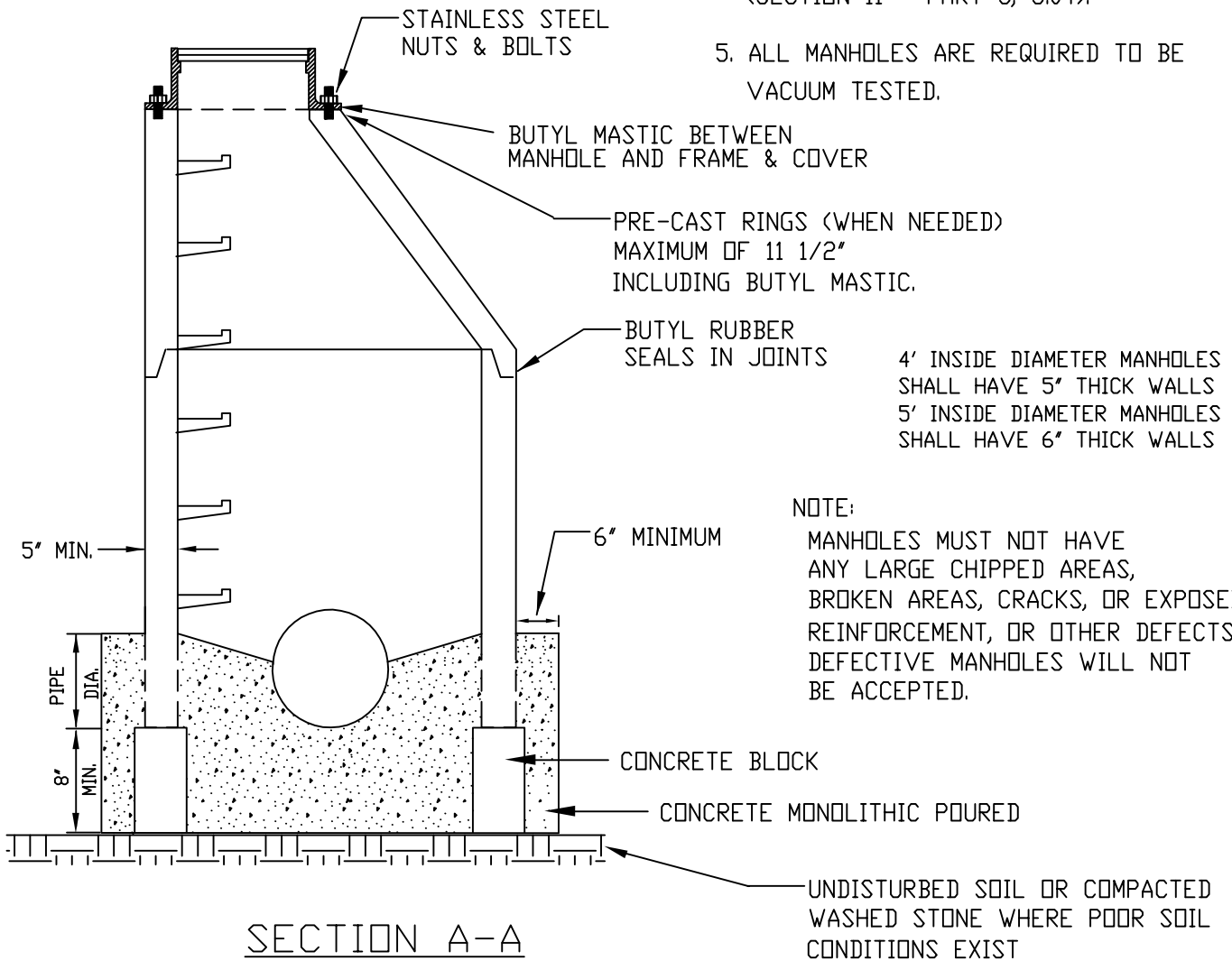

SECTION A-A

CITY OF SALISBURY, N.C. STANDARD DETAIL

DATE: MAY 19, 2009

SEWER SYSTEMS
DOGHOUSE MANHOLE

NOT TO SCALE

STANDARD

SS-11