

DOUBLE CHECK VALVE ASSEMBLY (DCVA) 2" VAULT

VAULT SHALL BE
4" MIN. ABOVE
GROUND SEE NOTE 8

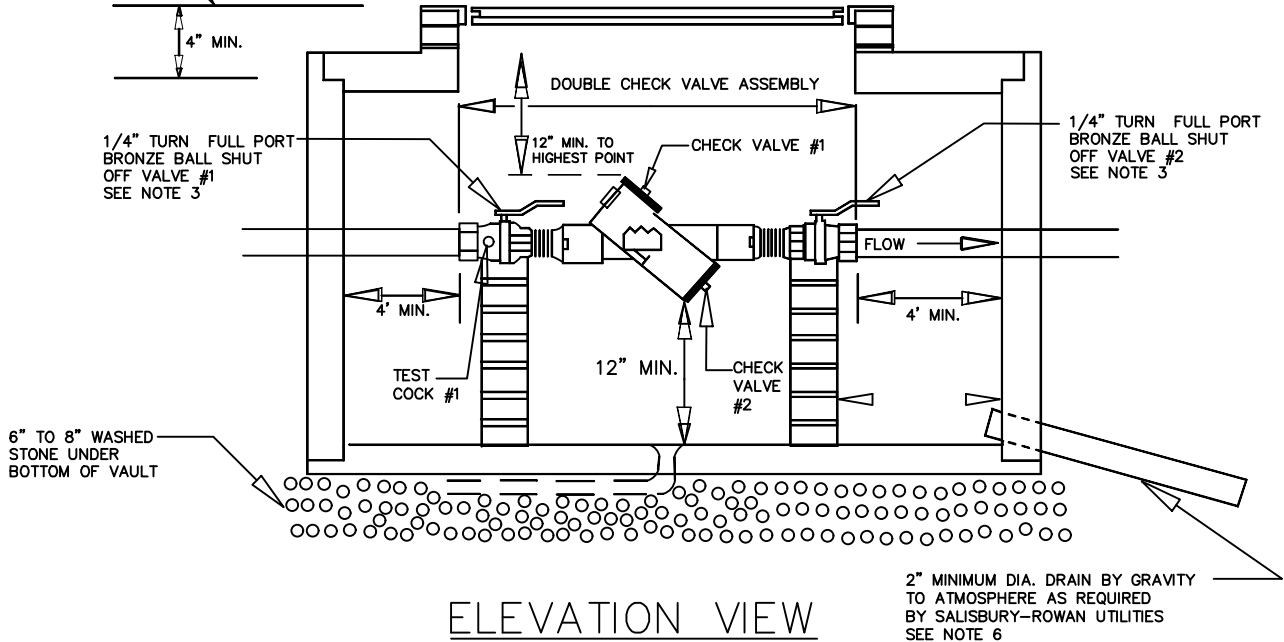

2" MINIMUM DIA. DRAIN BY GRAVITY
TO ATMOSPHERE AS REQUIRED
BY SALISBURY-ROWAN UTILITIES
SEE NOTE 6

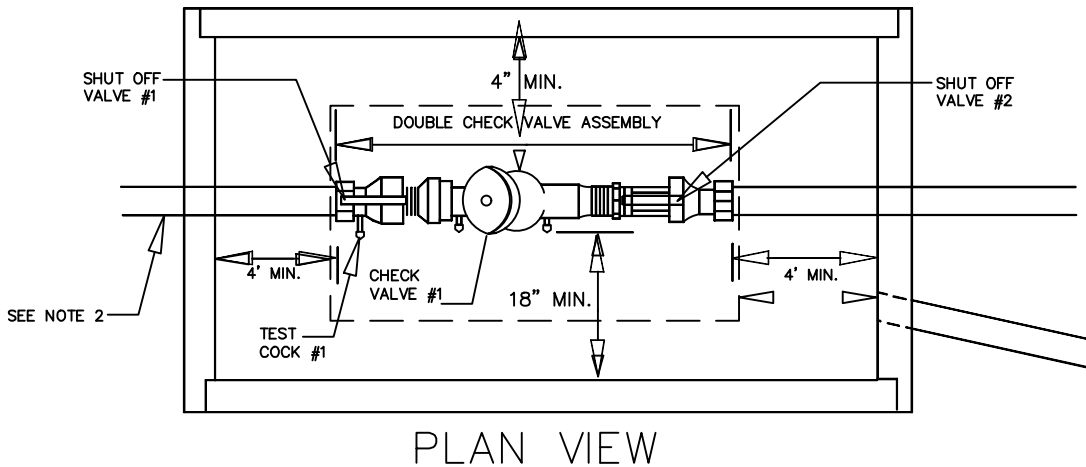

2" MINIMUM DIA. DRAIN BY GRAVITY
TO ATMOSPHERE AS REQUIRED
BY SALISBURY-ROWAN UTILITIES
SEE NOTE 6

NOTES:

1. DCVA MUST CONFORM TO SALISBURY-ROWAN UTILITIES SPECIFICATIONS FOR BACKFLOW PREVENTION ASSEMBLIES 1½" AND 2".
2. (BACKFLOW ASSEMBLY MUST BE INSTALLED BEFORE SERVICE LINE IS CONNECTED TO ANY OTHER PIPES, EXCEPT AS AUTHORIZED BY THE WATER PURVEYOR.) WATER LINE MUST BE EXPOSED FOR INSPECTION FROM METER TO BACKFLOW PREVENTER.
3. SALISBURY-ROWAN UTILITIES APPROVED DCVA'S INCLUDE SHUT OFF VALVES #1 AND #2. NO SUBSTITUTIONS SHALL BE PERMITTED.
4. TEST COCK #1 SHALL BE UPSTREAM OF SHUT OFF VALVE #1 AND IS TO BE PART OF THE APPROVED ASSEMBLY. ALL TEST COCKS MUST BE INSTALLED UPRIGHT AND IN THE HORIZONTAL POSITION.
5. VAULT, DOORS, OR COVERS AND SUPPORT OF ASSEMBLY SHALL BE DESIGNED BY OWNER AND AS REQUIRED.
6. DRAIN MAY BE PROVIDED AS SHOWN OR AS FLOOR DRAIN.
7. IF DRAINAGE CANNOT BE PROVIDED TO THE FREE ATMOSPHERE OR STORM DRAINAGE, THE DCVA'S SHALL BE INSTALLED ABOVE GROUND.
8. TOP OF VAULT SHALL BE 4" ABOVE GROUND. IF VAULT IS INSTALLED IN A TRAFFIC AREA AT GRADE LEVEL, THEN H20 TRAFFIC RATED VAULT AND LID SHALL BE INSTALLED. PRIOR APPROVAL IS REQUIRED FROM BACKFLOW ADMINISTRATOR FOR ANY VAULT TO BE LOCATED IN TRAFFIC AREA.

CITY OF SALISBURY, N.C. STANDARD DETAIL

DATE: OCTOBER 17, 2006
AMENDED: FEBRUARY 3, 2009

STANDARD DETAIL BACKFLOW PREVENTION
DOUBLE CHECK VALVE ASSEMBLY (DCVA) 2" VAULT

NOT TO SCALE
STANDARD BF-6