



TWO 1" DIA. HOLES FOR UNSEALED MANHOLES

DETAIL 1

TOP OF COVER

MINIMUM AVERAGE WEIGHT	
COVER	120 lbs.
FRAME	190 lbs.
UNIT	310 lbs.

BOTTOM OF COVER

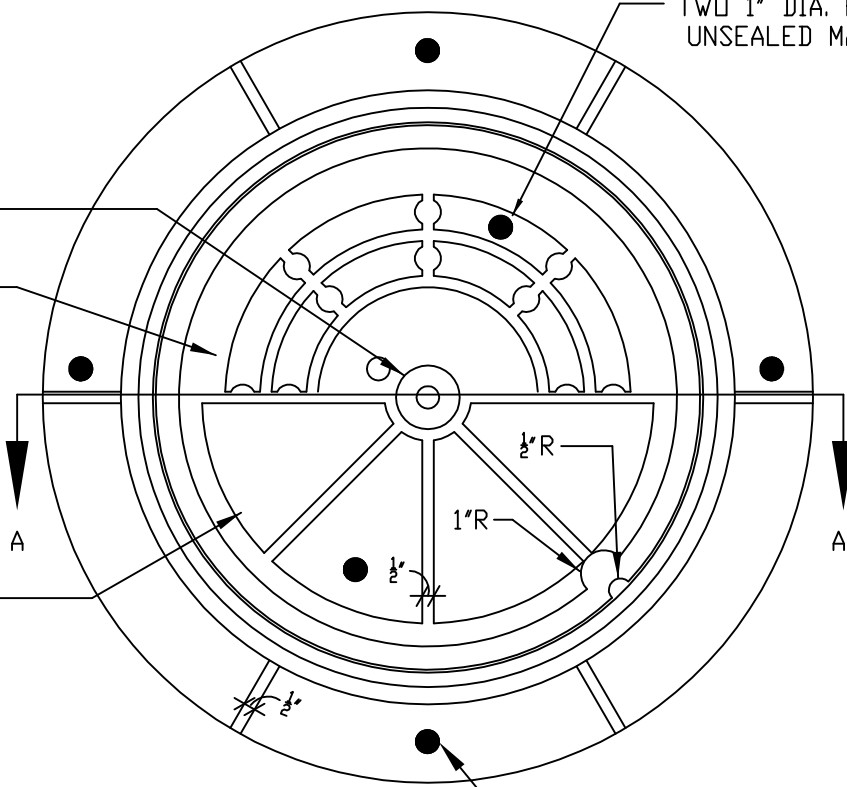

PLAN

BOLT HOLE

NOTES:

1. DIMENSIONS MAY VARY SLIGHTLY, BUT MANHOLE RING AND COVER ARE TO BE INTERCHANGEABLE WITH DIMENSIONS SHOWN.
2. HEAVY DUTY CAST IRON, ASTM 48-76 CLASS 35 MUST BE USA MADE
3. SEALED MANHOLES SHALL BE PROVIDED W/GASKETS AND A MINIMUM OF 4 BOLT DOWNS. TWO BOLTS SHALL BE CITY OF SALISBURY PATTERN LOCKING BOLTS AND TWO OF THE HEX-HEAD TYPE STAINLESS STEEL BOLTS
4. SEE CURRENT CITY OF SALISBURY WATER & SEWER APPROVED PRODUCT MANUFACTURER'S SHEET FOR APPROVED TYPES - LOCATED IN APPENDIX "A" OF THE CITY OF SALISBURY UNIFORM CONSTRUCTION STANDARDS

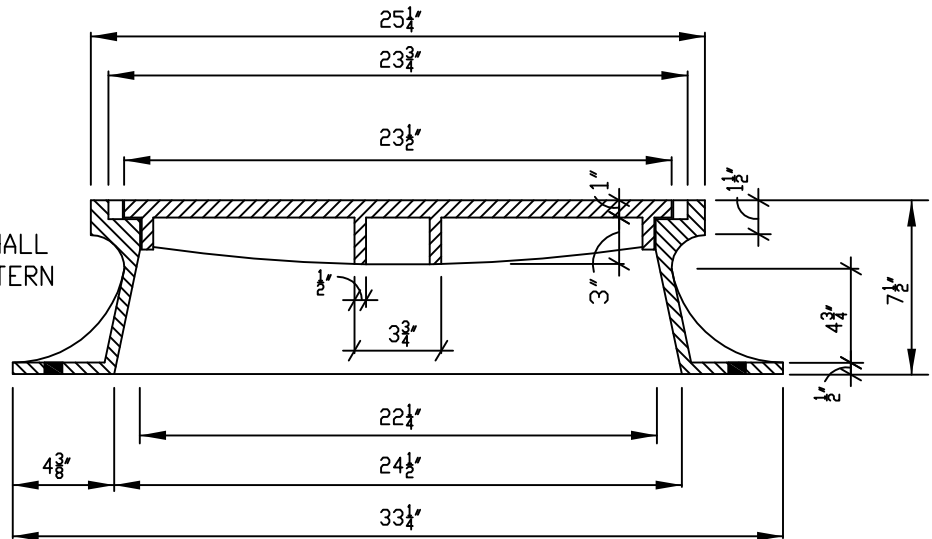

SECTION A-A

CITY OF SALISBURY, N.C. STANDARD DETAIL

DATE: OCTOBER 17, 2006

SEWER SYSTEMS
MANHOLE COVER

NOT TO SCALE

STANDARD

SS-6